

Saturday 4-13-24

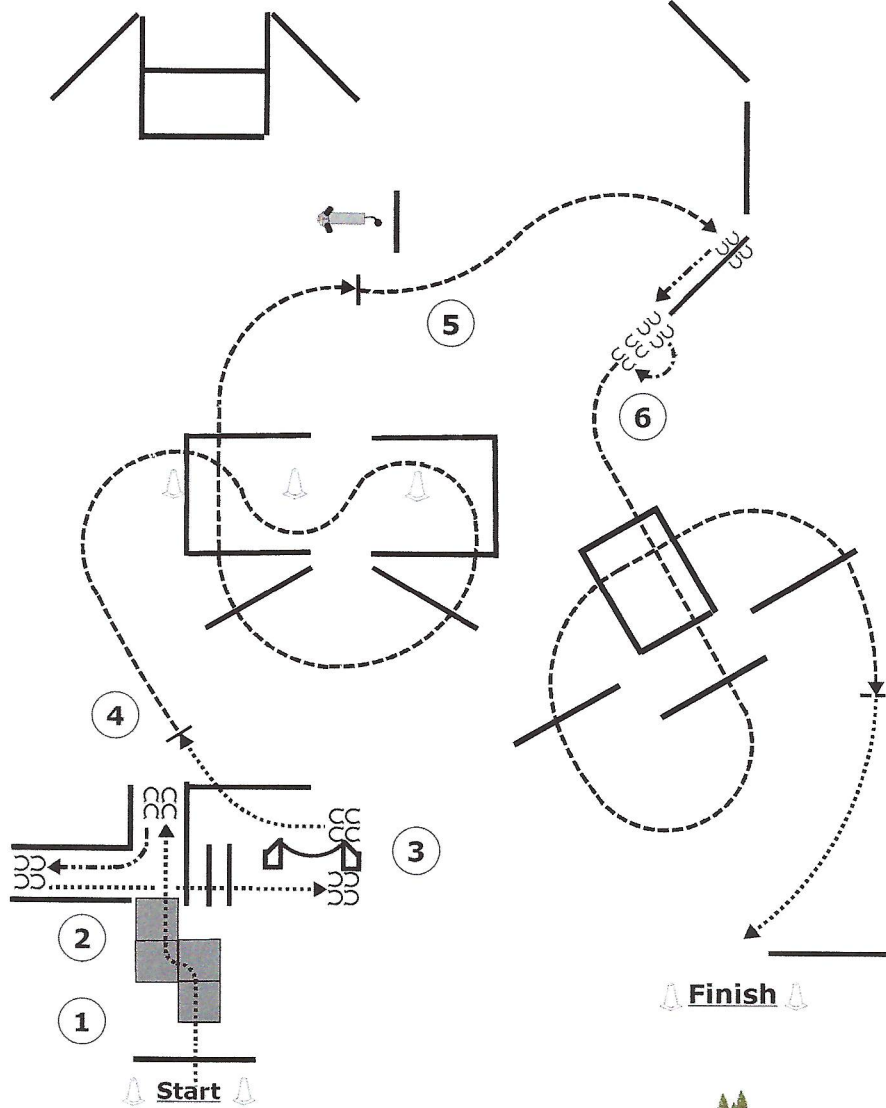

Course Design By:
Forrest McCallister
253-736-4045

- 1- Walk Bridge Into Chute
- 2- Back Chute
- 3- Walk Poles, Left Hand Push Gate, Walk Over Pole
- 4- Trot/Jog Poles
- 5- Trot/Jog Over Pole & Halt, Side Pass Right off Pole
- 6- 90° Haunch Turn Right, Trot/Jog Poles, Walk To Finish

Trail Class

- 229 - OTAB Trail In Hand All Ages/Types (NONPTHA)
- 230 - Mini A/B Trail In Hand
- 231 - Solid Mini A/B Trail In Hand
- 232 - Pony Trail In Hand
- 233 - Solid Pony Trail In Hand
- 234 - AM Mini A/B & Pony Trail In Hand 19 & Over
- 235 - YA Mini A/B & Pony Trail In Hand 18 & Under
- 238 - Pinto Yearling Trail In Hand- All Types

Saturday 4-13-24

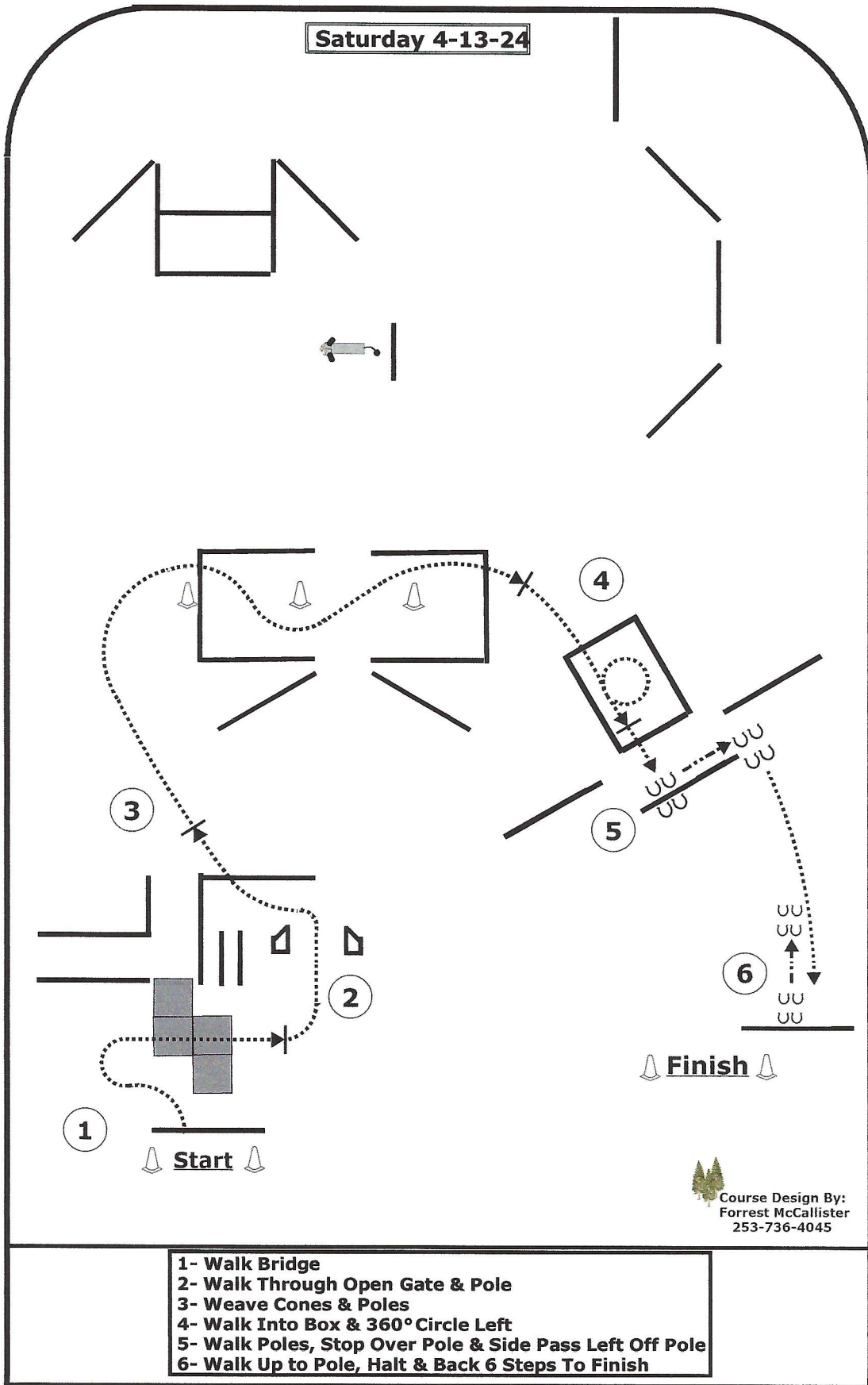

Course Design By:
Forrest McCallister
253-736-4045

- 1- Walk Bridge
- 2- Walk Through Open Gate & Pole
- 3- Weave Cones & Poles
- 4- Walk Into Box & 360° Circle Left
- 5- Walk Poles, Stop Over Pole & Side Pass Left Off Pole
- 6- Walk Up to Pole, Halt & Back 6 Steps To Finish

Trail Class
236 - Lead Line Trail 8 & Under

Saturday 4-13-24

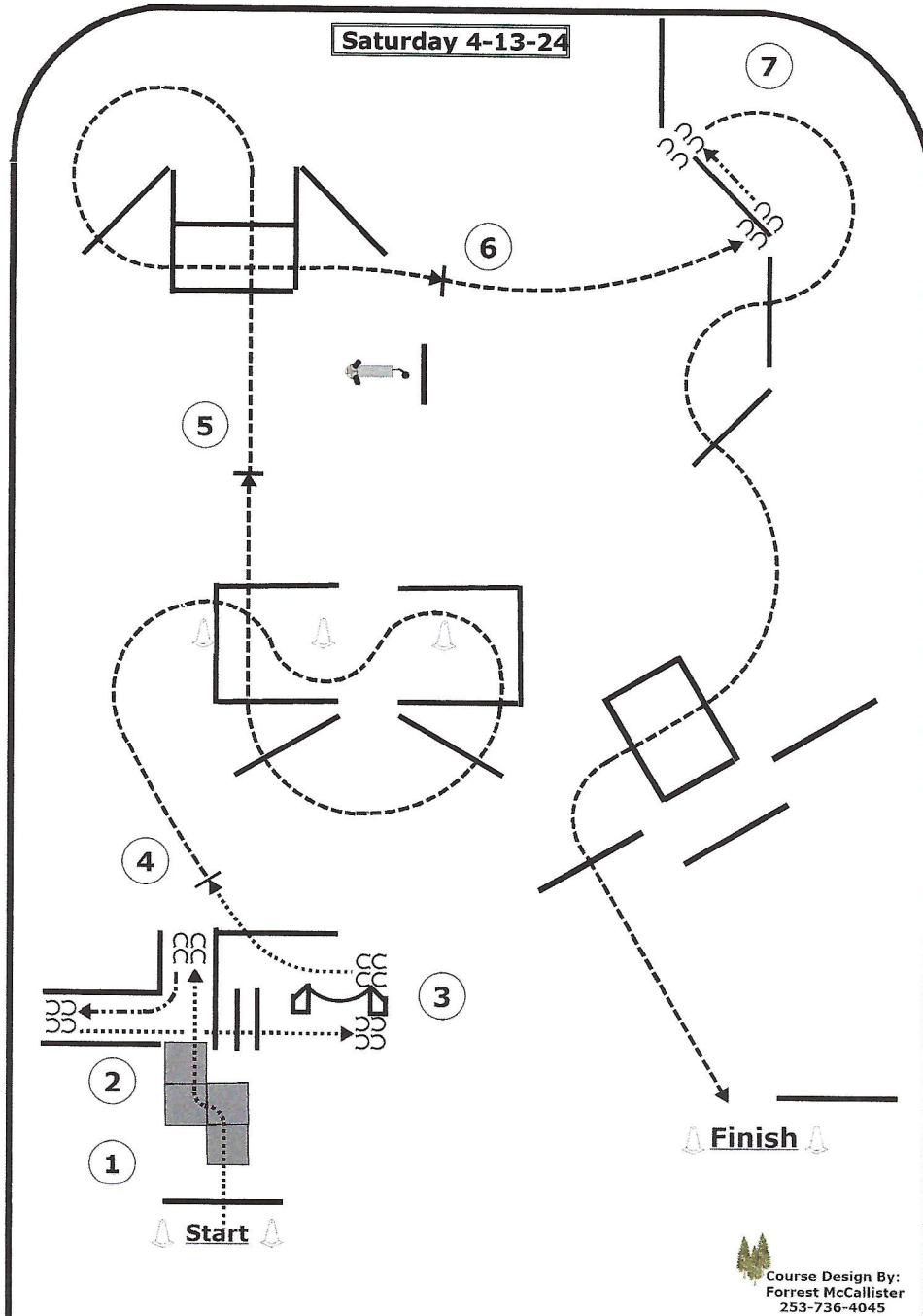

Course Design By:
Forrest McCallister
253-736-4045

- 1- Walk Pole & Bridge
- 2- Back Chute
- 3- Walk Poles & Left Hand Push Gate, Walk Over Pole
- 4- Trot/Jog Poles
- 5- Trot/Jog Poles
- 6- Trot/Jog & Halt Over Pole, Side Pass Left off Pole
- 7- Trot/Jog Poles To Finish, Halt

Trail Class

- 237- OTAB W/J All Ages/Types (NONPthA)
- 239- W/J YA Trail 10 & Under - All Types
- 240- W/J YA Trail 11-18 - All Types
- 241- W/J YA Trail 10 & Under Solid Registry
- 242- W/J YA Trail 11-18 Solid Registry
- 243- W/J AM Trail 19 & Over - All Types
- 244- W/J AM Trail 19 & Over Solid Registry

Saturday 4-13-24

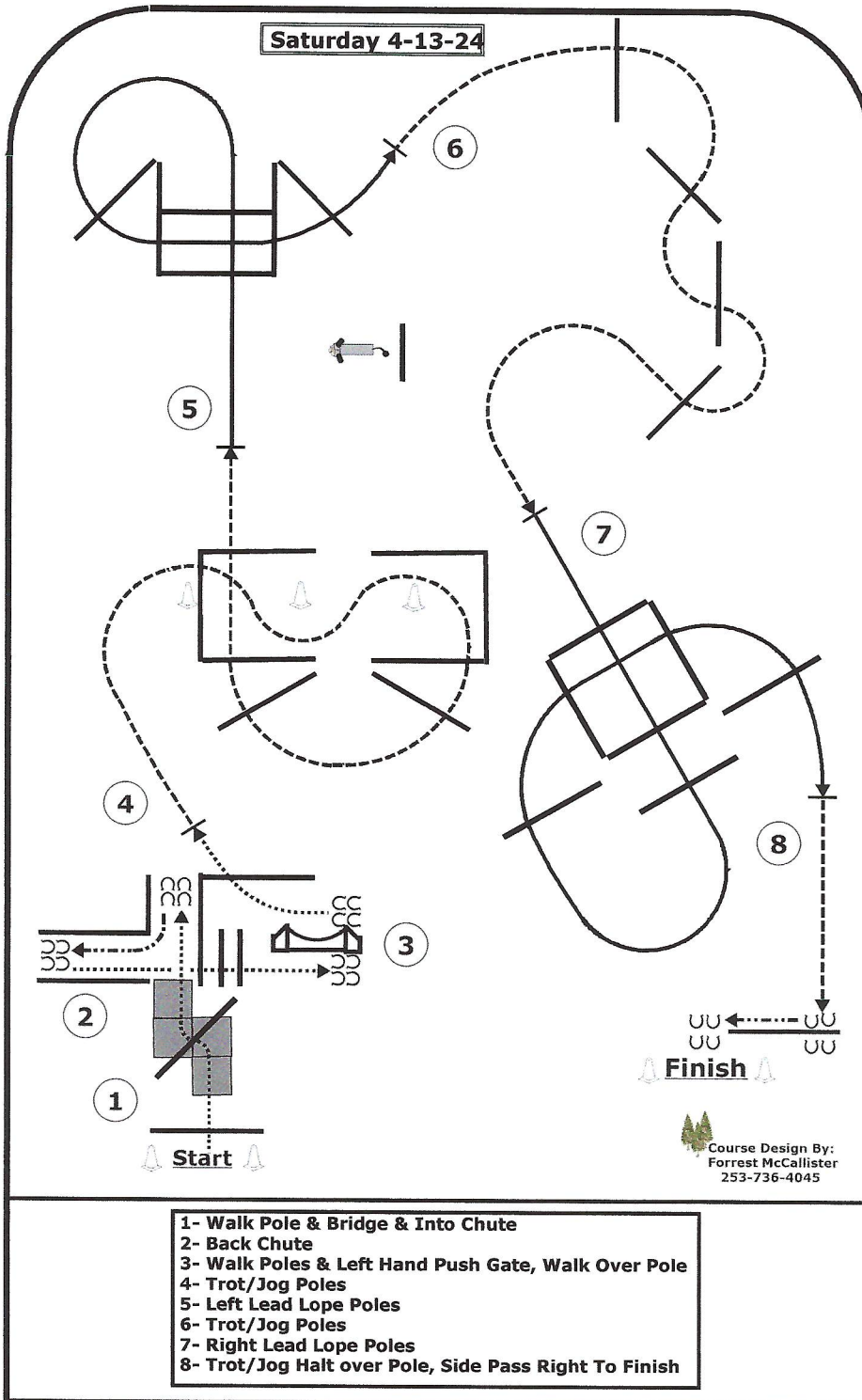

- 1- Walk Pole & Bridge & Into Chute
- 2- Back Chute
- 3- Walk Poles & Left Hand Push Gate, Walk Over Pole
- 4- Trot/Jog Poles
- 5- Left Lead Lope Poles
- 6- Trot/Jog Poles
- 7- Right Lead Lope Poles
- 8- Trot/Jog Halt over Pole, Side Pass Right To Finish

- Walk/Trot/Jog/Lope - All Trail Classes**
- 245 - OTAB Trail All Ages/Types (NONPthA)
 - 246 - Trail Solid Registry - All Types
 - 247 - Trail - All Types (SA/PL/ST/HU)
 - 248 - YA Trail 18 and Under - All Types
 - 249 - YA Trail Solid Registry 18 & Under - All Types
 - 250 - AM Trail 19 and Over - All Types
 - 251 - AM Trail Solid Registry 19 & Over - All Types
 - 252 - Novice AM Trail 19 & Over - All Types
 - 253 - Novice AM Trail 19 & Over Solid Registry
 - 254 - Novice YA Trail 18 & Under - All Types
 - 255 - Novice YA Trail 18 & Under Solid Registry

Saturday 4-13-24

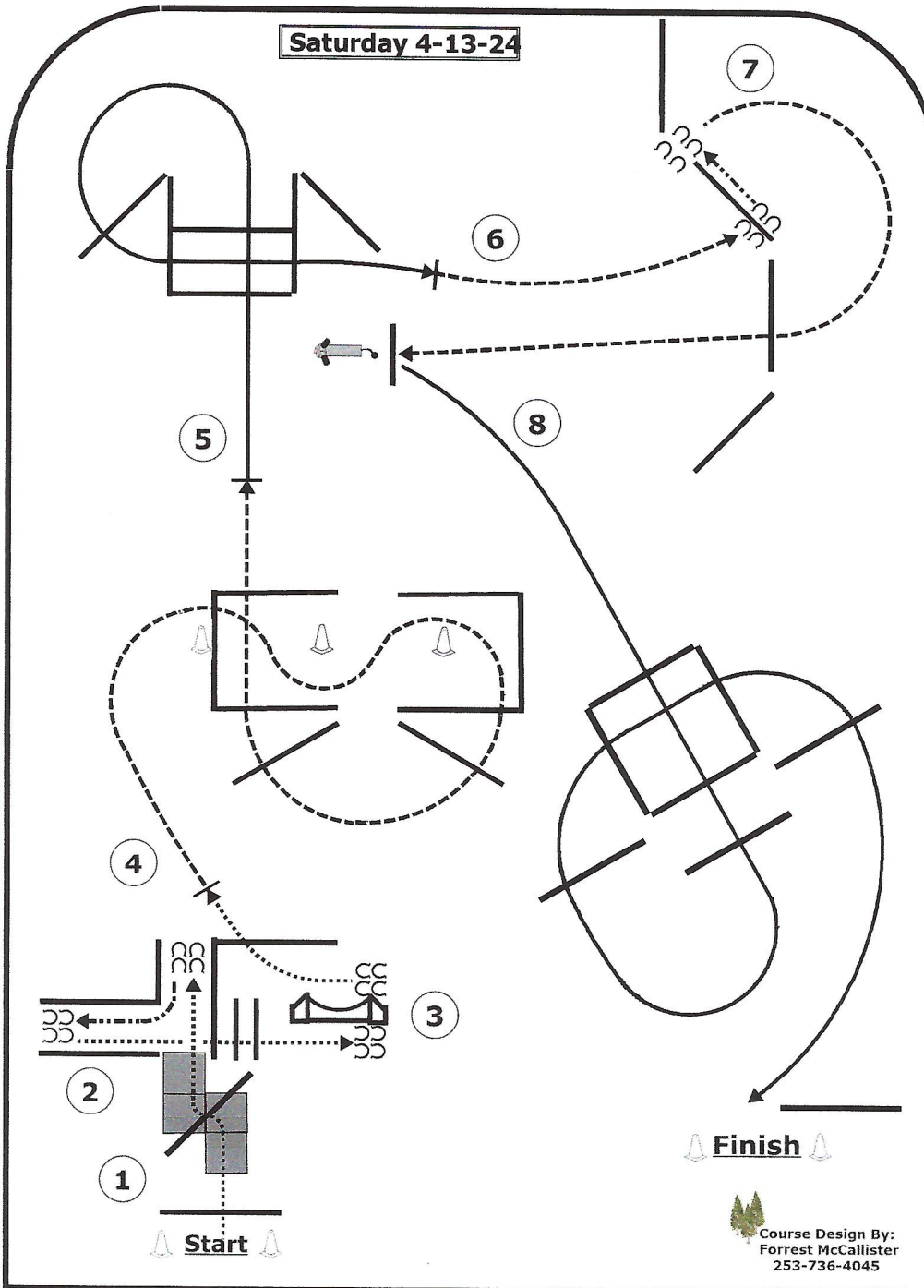

Finish

Course Design By:
Forrest McCallister
253-736-4045

- 1- Walk Pole & Bridge
- 2- Back Chute
- 3- Walk Poles & Left Hand Push Gate, Walk Over Pole
- 4- Jog Poles
- 5- Left Lead Lope Poles
- 6- Jog & Halt on Pole, Side Pass Left off Pole
- 7- Jog up to Cow, Rope Cow, Dally Rope, Drop Rope
- 8- Right Lead Lope Poles

Trail Class

- 256- Ranch Horse Trail Pinto - All types
- 257- Ranch Horse Trail Solid Registry - All types
- 258- AM Ranch Horse Trail 19 & Over - All types
- 259- AM Ranch Horse Trail 19 & Over - Solid Registry
- 260- YA Ranch Horse Trail 18 & Under - All types
- 261- YA Ranch Horse Trail 18 & Under - Solid Registry